

ecoline™-b

OIL WATER
SEPARATOR

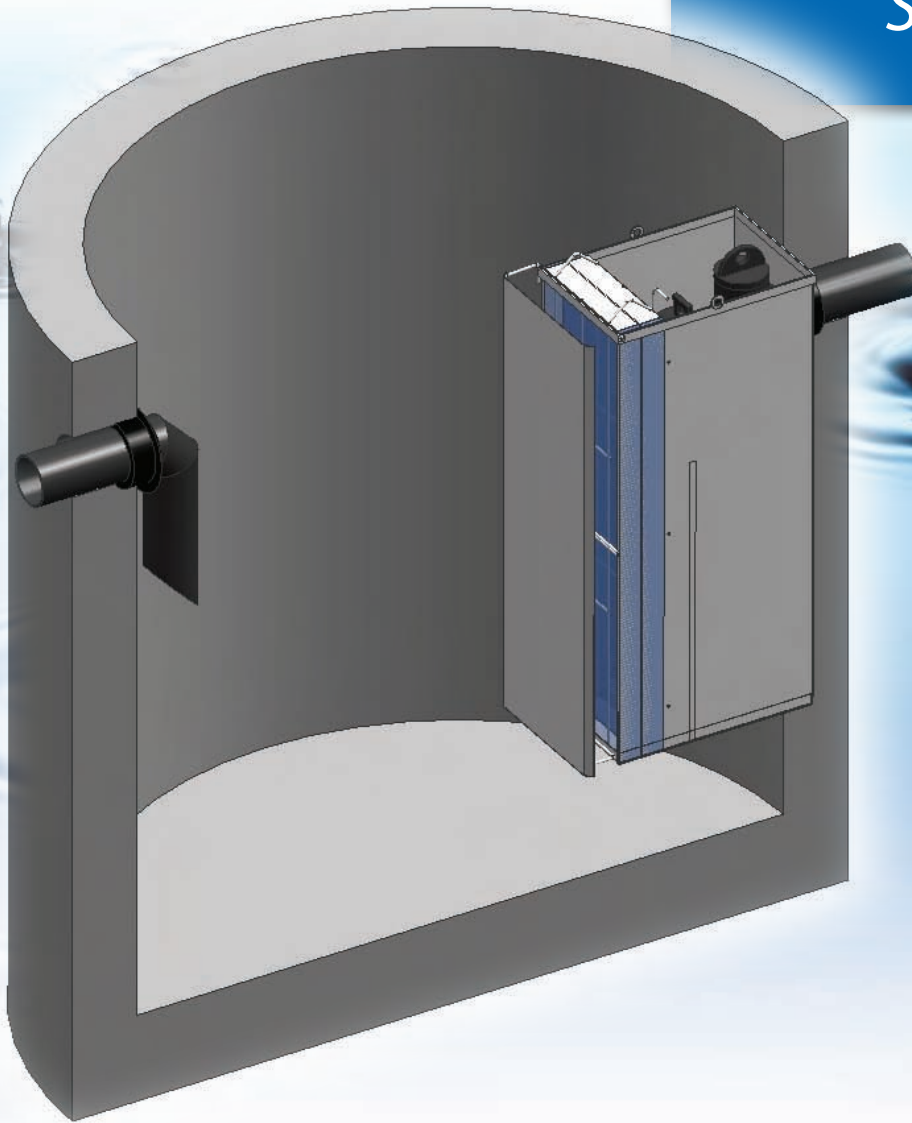

protect **TODAY** by
building for **TOMORROW**



ENVIRONMENTAL SYSTEMS, Inc.
A Division of Royal Enterprises America

ecoLine™-b

ecoLine™-b is a highly efficient and cost-effective below grade oil / water separator.

ecoLine™-b Benefits

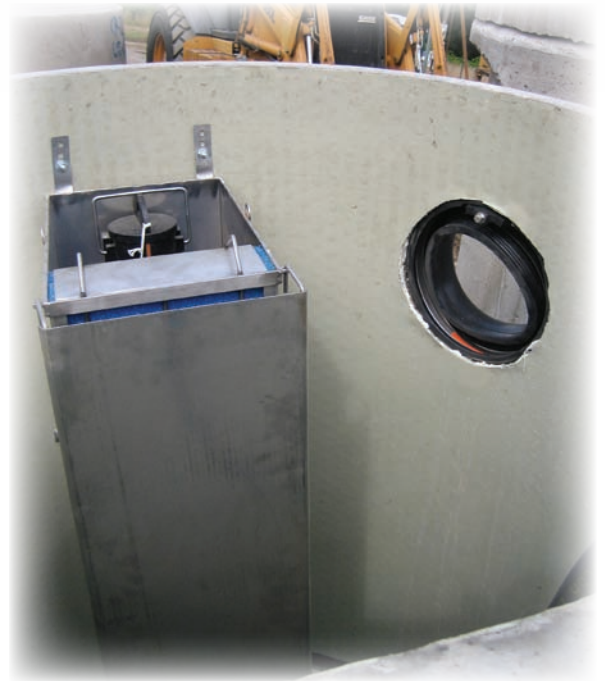
- *Designed for highly efficient free oil and hydrocarbon-laden sediment removal from contaminated water*
- *Separates to 5 ppm effluent oil content w/specific gravity below 0.95*
- *ecoLine-b's automatic shutoff valve closes the outlet pipe when the maximum oil storage capacity is reached*
- *Independent testing certifies the systems ability to provide clean water exceeding current environmental standards*
- *Allows for stricter, future point-source and industrial stormwater discharge guidelines with little or no modifications*
- *Non-mechanical / non-electrical system for high reliability*
- *Installation and maintenance friendly allowing access to all components from above ground*
- *Compact component design allows for quick assembly in new or existing structures*
- *Optimally designed for use in point source runoff (floor drains) and non-point source runoff from industrial areas (gas stations, maintenance facilities, electrical transformers, oil storage areas and others) containing significant loads of sediments and oils*
- *Low cost removal of virtually 100% pure oil collection*
- *Standard units provide 50, 160, 320, 640, 790 or 1110 GPM full flow treatment with manifold designs used for larger flow rates*



ecoLine™-b coalescing unit installed inside a lined precast concrete structure



ecoLine™-b in operation



ecoLine™-b in operation with heavy oil loading on water surface

The ecoLine™-b is designed to separate non-emulsified light liquids and low-water-soluble fluids with a specific gravity below 0.95, such as gasoline, diesel, heating oils and other mineral oils from effluent discharge.

ecoLine™-b Purification Process

Gravity Separation

In a two-tank design, an upstream grit chamber removes solids from the influent while compensating for temperature and oil concentration fluctuations as the initial phase of light fluid separation begins. The grit chamber is optional and systems can be designed without it based on site conditions.

Coalescing Media

Within the coalescing media, fine droplets too small to separate by gravity alone accumulate into bigger drops which eventually become buoyant enough to rise to the surface. The separated effluent contains a free petroleum content of less than 5 ppm oil concentration. The coalescing media, housed in a stainless steel cartridge is easily removed for cleaning / rinsing and replaced for continued service.

Spill Control

An automatic shutoff valve closes the outlet pipe when the maximum oil storage capacity is reached.

Optional Oil Level Sensor

Units can be equipped with an optional oil level sensor, which activates an alarm once the maximum oil storage capacity of the system is reached.

Optional Automatic Draw-off Device (ADD)

An Automatic Draw-off Device can be added for continuous removal of collected oil for storage in an oil recipient.

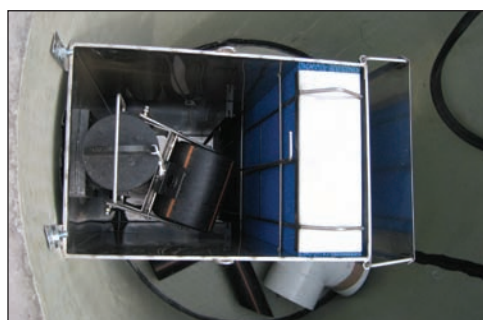
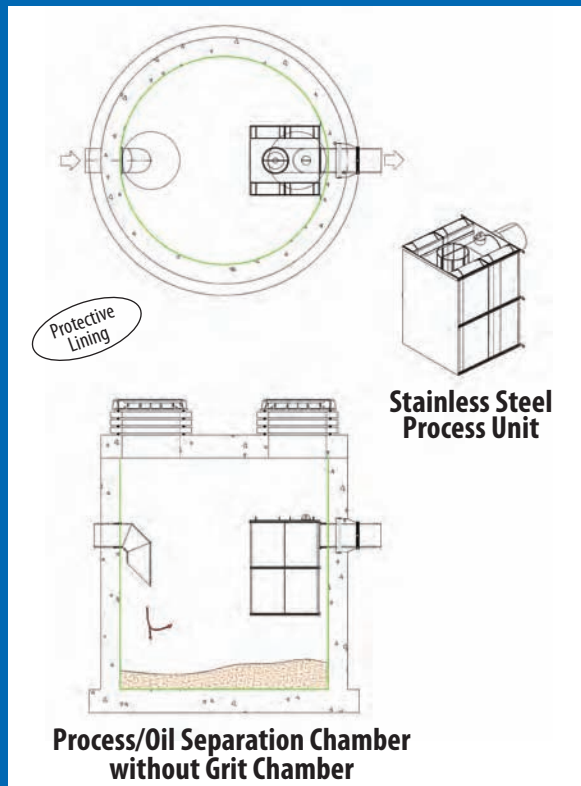

ecoLine™-b coalescing outlet structure with automatic shutoff valve

ecoLine™-b Model Sizing

Treatment Flowrate (GPM)	Coalescing Structure Diameter	Grit Structure Diameter
50	48"	48"
160	72"	48"
320	84"	60"
640	96"	60"
790	120"	96"
1110	120" (2 each)	120"

www.royalenterprises.net

ROYAL ENTERPRISES AMERICA

Royal Environmental Systems, Inc.

"Innovative technological products revolutionizing stormwater pollution control"

Royal Concrete Pipe, Inc.

"Providing quality concrete products since 1990"

Royal Erosion Control Systems, LLC

"Concrete block mat system for the prevention of soil erosion"

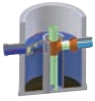

ecoStorm®

Gravity separation stormwater treatment system



ecoStorm^{plus}®

Gravity separation *plus* upflow adsorptive stormwater filtration



ecoStop®

Catastrophic hydrocarbon spill control system



ecoSep®

Below-grade, high efficiency oil/water separators



ecoLine™-b

Above-grade, high efficiency oil/water separators



ecoTop™



ecoLine™-a



RoadSide ACIST™

Portable stormwater treatment system for turbidity and pH management



TRITON
STORMWATER SOLUTIONS

Underground stormwater detention & infiltration system



InfraSafe®
Sediment Control Barrier

Storm sewer inlet sediment control products



Cable Concrete™

Articulating concrete block revetment system



IntraFlow®
Low-Profile Inside Drop System

Sanitary sewer inside drop system

www.royalenterprises.net

Office: 651.462.2130

Fax: 651.462.6990

Email: support@royalenterprises.net

Toll Free: 1.800.817.3240

Royal Enterprises America

30622 Forest Boulevard

PO Box 430

Stacy, MN 55079

Royal
ENVIRONMENTAL SYSTEMS, Inc.
A Division of Royal Enterprises America